

# XeNTIS

carbon wheel technology



Patric Grüner - RAAM

2018 | CARBON WHEEL TECHNOLOGY. Handmade in Austria





 **CARBON WHEEL TECHNOLOGY.** Handmade in Austria

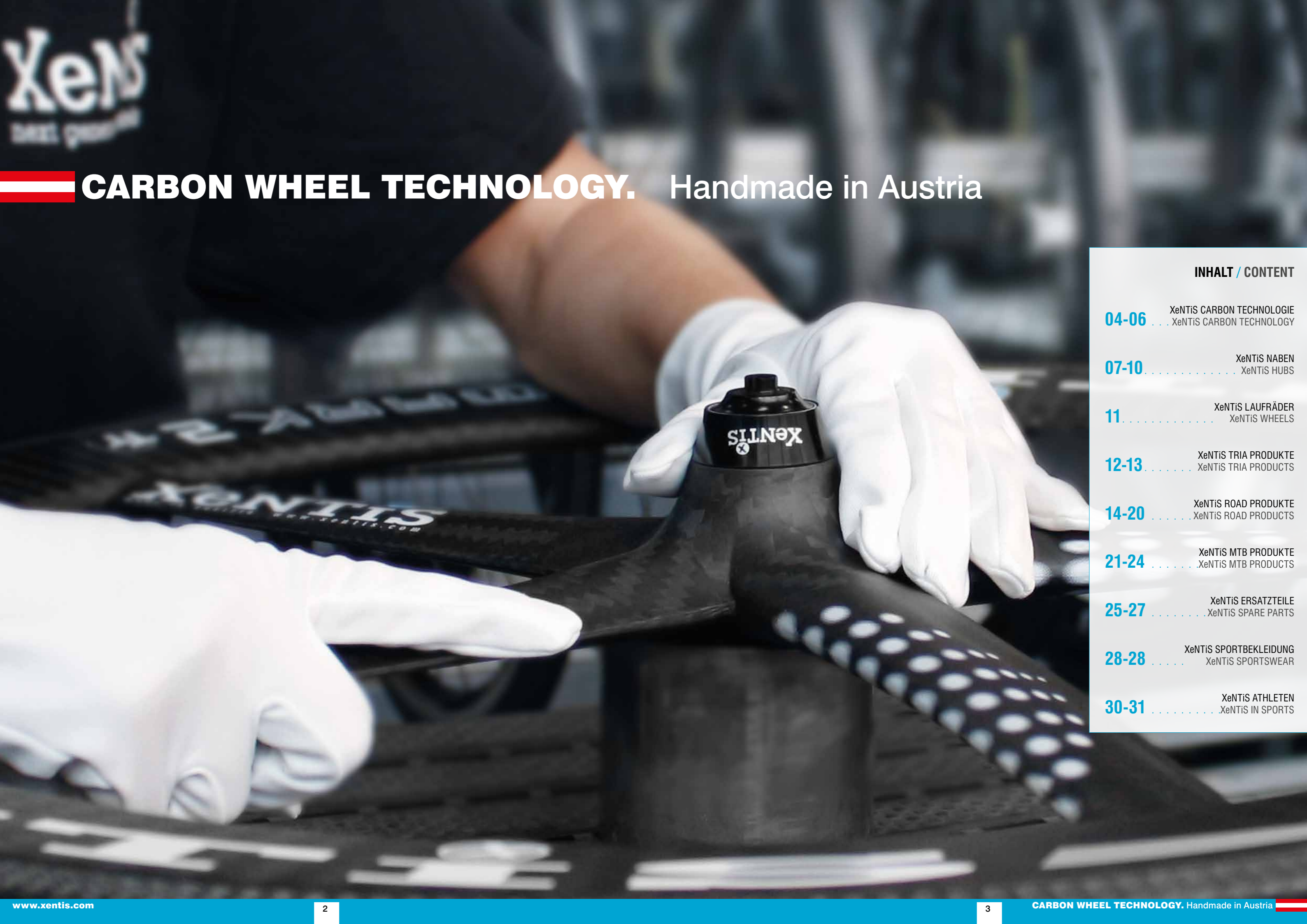

**INHALT / CONTENT**

<b>04-06</b>	XeNTIS CARBON TECHNOLOGIE XeNTIS CARBON TECHNOLOGY
<b>07-10</b>	XeNTIS NABEN XeNTIS HUBS
<b>11</b>	XeNTIS LAUFRÄDER XeNTIS WHEELS
<b>12-13</b>	XeNTIS TRIA PRODUKTE XeNTIS TRIA PRODUCTS
<b>14-20</b>	XeNTIS ROAD PRODUKTE XeNTIS ROAD PRODUCTS
<b>21-24</b>	XeNTIS MTB PRODUKTE XeNTIS MTB PRODUCTS
<b>25-27</b>	XeNTIS ERSATZTEILE XeNTIS SPARE PARTS
<b>28-28</b>	XeNTIS SPORTBEKLEIDUNG XeNTIS SPORTSWEAR
<b>30-31</b>	XeNTIS ATHLETEN XeNTIS IN SPORTS





## Carbon Technologie aus der österreichischen Edelschmiede

Es gibt ein Material, das mehr leistet als andere. Ein Hochleistungswerkstoff, mit dem ein Unternehmen arbeitet wie kaum ein anderes. XeNTiS fertigt aus Carbon, Rims, Wheels und Komponenten in unnachahmlicher Form und Funktion.

XeNTiS ist mit dem Anspruch angetreten, neue Maßstäbe zu setzen. Jahrelanges Know-how im Umgang mit Carbon fließt in die größtenteils manuelle Fertigung ein.

Unverzichtbar sind dabei die Erfahrungen erfolgreicher Athleten. Sie treiben die permanente Entwicklung von Wheels und Komponenten voran. So wurden die Squad SL Modelle in Zusammenarbeit mit dem besten österreichischen Radrennenteam (Team Felbermayr-Simplon Wels) realisiert.

Die Umsetzung erfolgt mittels CAD und FE Berechnungssysteme. Prototypen werden konstruiert und analysiert.

Erst wenn die entsprechenden Ergebnisse vorliegen, kommen die neuen Wheels zu den computergestützten Aerodynamik Tests, die abschließend mit Ergebnissen des Prototypen aus dem Windkanal überprüft werden.

## Carbon Technology from the Austrian high end manufacturer

There is a material that performs better compared to others. Carbon composite is a high-end performance material. XeNTiS uses it to produce carbon wheels, rims and components unlike any other.

XeNTiS claims to set new standards. Many years of expertise in dealing with carbon flows into the largely hand crafted production lines.

Essential are also the experiences of successful athletes as they are the drive behind the permanent development of XeNTiS wheels and components. The Squad SL is the result of a close cooperation with the leading Continental-Racing Team Felbermayr-Simplon Wels from Austria. The implementation takes place by means of CAD and FE calculation systems, then prototypes are constructed and further analyzed.

Only if the relevant results meet or exceed expectations, the data will be transmitted to the computerized aerodynamic test bench and finally the result are directly compared to the result of the prototype in the wind tunnel.



Die patentierte Bremsfläche von XeNTiS garantiert beste Bremsperformance bei nassen und trockenen Bedingungen. Es kommt zu keinem Verschleiß der Bremsfläche.

The patented brake surface guarantees the best brake performance in wet and dry conditions. No wear-out on the brake surface.



XeNTiS verbessert die Aerodynamik durch den ACTIVE TURBULATOR (Welle).

XeNTiS improves aerodynamics using the ACTIVE TURBULATOR (Wave)



XeNTiS Wheels werden zu 100% in Österreich gefertigt und verfügen über einen RFID Chip. Dieser garantiert die Nachverfolgbarkeit von Herkunft und Herstellung.

XeNTiS wheels are 100% hand made in Austria. All wheels are fitted with a unique RFID chip that allow exact information to be traced and extracted such as origin and manufacturing specifications.



XeNTiS Squad SL und Monocoque Wheels werden lackiert und sind daher UV-beständig.

XeNTiS Squad SL and monocoque wheels are coated and therefore UV protected.

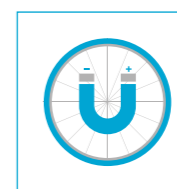

XeNTiS Wheels sind ausbalanciert und verfügen über einen integrierten Tachomagneten. (kein Tachomagnet in den Modellen RACE 2.5 und SL 2.5)

XeNTiS wheels are harmonically balanced and feature an integrated tachometer magnet. (No tachometer magnet in RACE 2.5 and SL 2.5)

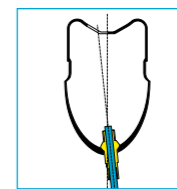

Aufgrund von XeNTiS Spezialbohrungen im Inneren der Felge wird eine sehr hohe Haltbarkeit und eine optimale und langlebige Kraftübertragung garantiert. Durch diese Bearbeitung wird das Eindringen von Wasser in die Felge verhindert.

Due to the XeNTiS offset holes inside the rim, the durability of XeNTiS wheels is very high. These holes guarantee an optimal and durable power transfer and this process prevents penetration of water into the rim.

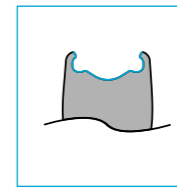

Durch das TUBELESS READY System können alle XeNTiS Clincher Laufäder ohne Schlauch gefahren werden. Aufgrund der speziellen Felgenbettgeometrie sitzt der Reifen exakt im Felgenhorn. Der Einsatz dieses Systems erhöht wesentlich die Pannensicherheit und den Komfort.

Due to the TUBELESS READY system all XeNTiS clincher wheels are rideable without an inner tube. Because of the special rim base the tyre fits exactly to the rim flange. This application guarantees a significant increase in puncture protection and riding comfort.

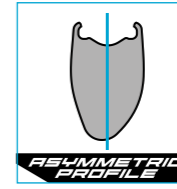

Der ASYMMETRISCHE FELGENQUERSCHNITT kommt bei Hinterrad- und Scheibenbremsnaben zum Einsatz, nähert die Speichenspannung links und rechts aneinander an und erhöht dadurch die Seitensteifigkeit des gesamten Laufrades.

The ASYMMETRIC RIM PROFILE is used in combination with rear and disc-brake hubs. As a result, the spoke tension left and right is almost equal and therefore the lateral stiffness of the entire wheel increases.

# PATENTED BRAKE SURFACE

## Patentierte XeNTiS Bremsperformance (XBP)

Die patentierte Bremsfläche von XeNTiS garantiert beste Bremsperformance bei nassen und trockenen Bedingungen. Es kommt zu keinem Verschleiß der Bremsfläche und neben den XeNTiS Bremsbelägen ist auch die Verwendung von Standardbremsbelägen möglich.

## Patented XeNTiS brake performance (XBP)

The patented brake surface guarantees the best brake performance in wet and dry conditions. No wear-out on brake surfaces and in addition to XeNTiS brake pads, standard brake pads can be used too.

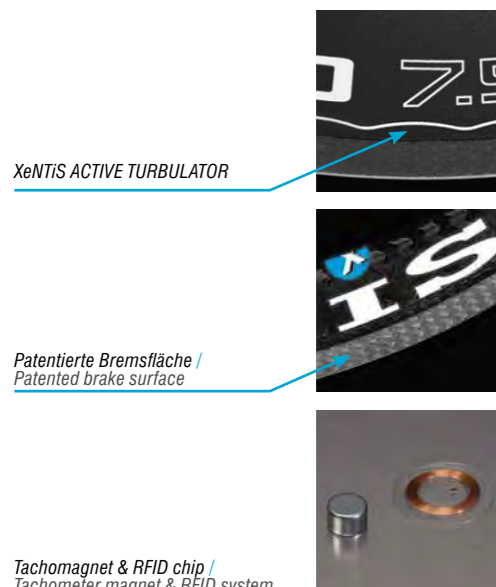

XeNTiS ACTIVE TURBULATOR

Patentierte Bremsfläche / Patented brake surface

Tachomagnet & RFID chip / Tachometer magnet & RFID system



XeNTiS Bremsbeläge / XeNTiS brake pads

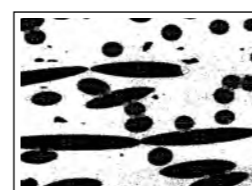

Computerunterstützt verarbeitete optische (vergrößerte) Aufnahme der Oberfläche des Bremsbereiches. / Computer-aided optically processed (enlarged) image of the surface of the brake sector.



Abb.XBP / figure XBP  
Abb. XBP zeigt die typische Materialbeschaffenheit des Verbundmaterials nach dem Urformprozess in der Felgenflanke vor und nach der erfindungsgemäßen Bearbeitung. / Fig. XBP shows the typical nature of the composite material after the primary shaping process in the rim edge before and after processing according to the patented labor process.

- 1 Felge / rim
- 2 Bremsbereich / brake sector
- 3 Felgenkörper / rim body
- 6 Oberfläche des Bremsbereiches (vor der mech. Bearbeitung) / surface of brake sector (before mechanical processing)
- 7 Span / blade
- 8 Spanwerkzeug (Keil) / cutting tool (wedge)
- 9 mechanisch veredelte Oberfläche / mechanically refined surface
- 10 Carbonfaser / carbon fiber
- 11 Kunstharz / synthetic resin
- 16 Schleifscheiben (topfförmig) / grinding disc (cup-shaped)
- 17 Schnitt durch Schleifscheibe / profile of grinding disc

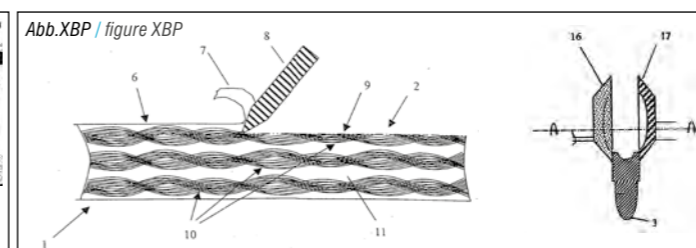

## Squad Race

SQUAD Race ist die neue Serie von XeNTiS und ersetzt die Modellreihe XBL. Diese Modelle sind in drei verschiedenen Felgenhöhen (25, 42 und 58 mm) und jeweils als Clincher mit tubeless ready System und als Tubular Variante erhältlich.

Das größte Novum im Vergleich zur XBL Modellreihe ist die Anhebung der Felgenbreite auf 26 mm. Zusätzlich kommen erstmalig asymmetrische Felgenprofile zum Einsatz welche die Seitensteifigkeit erhöhen.

Durch die Zusammenarbeit mit DT Swiss sind diese Laufräder wahlweise mit Naben des Schweizer Qualitätsherstellers in den Ausführungen Felgenbremse und Scheibenbremse (Centerlock) erhältlich.

## Relaunch der Squad SL Serie

Die SL Modelle sind in vier Felgenhöhen (25, 42, 58 und 75 mm) als Clincher mit tubeless ready System und als Tubular Variante (ausgenommen 75 mm) erhältlich.

Neben der bei XeNTiS hausintern entwickelten und produzierten Carbonnabe (Vorderrad) wird bei der Hinterrad Nabe, wie bei der Race Linie, auf DT Swiss gesetzt.

Zur unkomplizierten Wartung der Laufräder sind diese mit außenliegenden Nippeln versehen.

## Relaunch der Squad MTB 29er Serie

Zusätzlich zum Hookless Laufrad SQUAD MTB 3.0 ist ab sofort auch das konventionelle Clincher Modell mit breiterer Felge und als Boost Standard erhältlich. Alle MTB Laufräder werden mit außenliegenden, selbstsichernden Nippeln geliefert.

## Squad Race

SQUAD Race is the new line of XeNTiS and replaces the XBL model range. These wheels are available in three different rim depths (25, 42 and 58 mm) and they are offered as clincher with integrated tubeless ready system and as tubular wheels.

The most innovative feature in comparison to the XBL line is the increase of the rim width to 26mm. Furthermore, we developed an asymmetric rim design which increase the lateral stiffness significantly.

Due to a cooperation with DT Swiss, the customer can choose between rim and disc brake (centerlock) from the Swiss quality manufacturer.

## Relaunch der Squad SL Serie

The SL wheels are available in four different rim depths (25, 42, 58 and 75 mm). All sizes are offered as clincher wheels with integrated tubeless ready system, the three lower ones are obtainable as tubular wheels as well.

Additionally to the in-house developed and manufactured XeNTiS carbon hub (front) a rear hub, produced by DT Swiss, is built in the wheel set.

To guarantee a simpler maintenance process the wheels are assembled with external nipples.

## Relaunch der Squad MTB 29er Serie

In addition to the hookless wheel SQUAD MTB 3.0 the conventional clincher model is obtainable with a wider rim and in combination with boost hubs. All MTB wheels are supplied with external nipples including an integrated threadlock system.

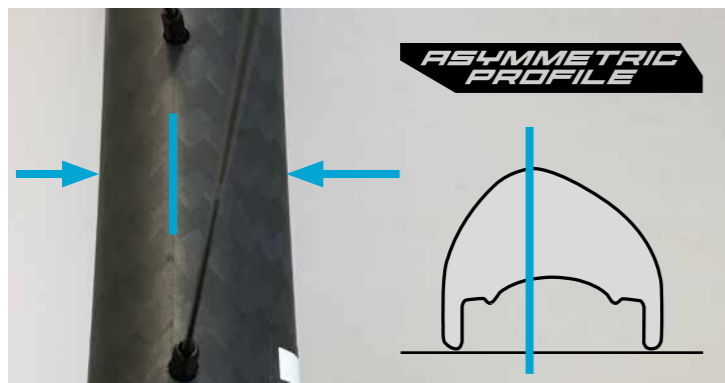

asymmetrisches Felgenprofil / asymmetric rim design



außenliegende, selbstsichernde Nippel / external nipples, integrated threadlock system



breitere Felge / wider rim

## XeNTiS Naben

Die XeNTiS Entwicklung beschränkt sich nicht nur auf die Produktion hochwertiger Carbonfelgen, sondern erstreckt sich auch auf die Entwicklung und Herstellung haus eigener Naben. Erweitert wird die Produktpalette durch die Zusammenarbeit mit DT Swiss.



Langzeittest, Prüfstandtest und letztendlich Renneinsätze, tragen zum Ergebnis bei.





## XeNTiS hubs



The XeNTiS development is not limited to the production of high quality carbon rims, but also extends to the development and manufacture of in-house hubs. The product range is extended by the cooperation with DT Swiss.



Long-term tests, bench testing and ultimately racing commitments contribute to the excellent results.





XeNTIS SQUAD RACE	specifications rear wheel	specifications front wheel
		
surface	black anodized	black anodized
range of use	ROAD SQUAD 2.5 / 4.2 / 5.8 RACE	
quick release	QR5-130mm	QR5-100mm
body material	aluminium	aluminium
hub flange	straight pull	straight pull
axle	Ø 15 mm aluminium axle	Ø 9 mm aluminium axle
ball bearing	4 ball bearings , sealed twice	2 ball bearings , sealed twice
compatibility	Campagnolo 9/10/11-Speed Shimano 9/10/11-Speed, SRAM 10/11-Speed	
weight	264 g	110 g

XeNTIS SQUAD SL	specifications rear wheel	specifications front wheel
 		
surface	black anodized	matt coated
range of use	ROAD SQUAD 2.5 / 4.2 / 5.8 SL	
quick release	QR5-130mm	QR5-100mm
body material	aluminium	aluminium
hub flange	straight pull	straight pull
axle	Ø 15 mm aluminium axle	Ø 15 mm aluminium axle
ball bearing	4 ball bearings , sealed twice	2 ball bearings , sealed twice
compatibility	Campagnolo 9/10/11-Speed Shimano 9/10/11-Speed, SRAM 10/11-Speed	
weight	212 g	59 g



XeNTIS SQUAD RACE DISC BRAKE	specifications rear wheel	specifications front wheel
		
surface	black anodized	black anodized
range of use	ROAD SQUAD 2.5 / 4.2 / 5.8 RACE	
quick release	QR5-135mm, X10-135mm, X12-135mm, X12-142mm	QR9-100, QR12-100, QR15-100,
body material	aluminium	aluminium
hub flange	straight pull	straight pull
disc brake adaptor	center lock	center lock
axle	Ø 15 mm aluminium axle	Ø 15 mm aluminium axle
ball bearing	4 ball bearings , sealed twice	2 ball bearings , sealed twice
compatibility	Campagnolo 9/10/11-Speed Shimano 9/10/11-Speed, SRAM 10/11-Speed SRAM XX1	
weight	267 g	136 g



XeNTIS SQUAD MTB	specifications rear wheel	specifications front wheel
		
surface	black matt anodized or white matt anodized	
range of use	SQUAD MTB, KAPPA2	
quick release	QR5-135mm, X10-135mm, X12-135mm, X12-142mm	QR5-100, QR9-100, QR12-100, QR15-100
body material	aluminium	aluminium
hub flange	straight pull	straight pull
disc brake adaptor	6-hole IS 2000	6-hole IS 2000
axle	Ø 17 mm aluminium axle	Ø 15 mm aluminium axle
ball bearing	4 ball bearings , sealed twice	2 ball bearings , sealed twice
compatibility	Campagnolo 9/10/11-Speed Shimano 9/10/11-Speed, SRAM 10/11-Speed SRAM XX1	
weight	212 g	114 g

XeNTIS SQUAD MTB	specifications rear wheel	specifications front wheel
		
surface	black matt anodized or white matt anodized	
range of use	SQUAD MTB BOOST	
quick release	X12-148 mm	QR15-110 mm
body material	aluminium	aluminium
hub flange	straight pull	straight pull
disc brake adaptor	6-hole IS 2000	6-hole IS 2000
axle	Ø 17 mm aluminium axle	Ø 15 mm aluminium axle
ball bearing	4 ball bearings , sealed twice	2 ball bearings , sealed twice
compatibility	Campagnolo 9/10/11-Speed Shimano 9/10/11-Speed, SRAM 10/11-Speed SRAM XX1	
weight	230 g	120 g



# XeNTiS WHEELS

XeNTiS SQUAD MTB	specifications rear wheel	specifications front wheel
 <p>XeNTiS XH002 XH002 LE</p>		
surface	black mat anodized or white mat anodized	
range of use	SQUAD MTB Lefty	
quick release	QR5-135mm, X10-135mm, X12-135mm, X12-142mm	Lefty Super Max 2.0
body material	aluminium	aluminium
hub flange	straight pull	straight pull
disc brake adaptor	6-hole IS 2000	6-hole IS 2000
axle	Ø 17 mm aluminium axle	-
ball bearing	4 ball barings , sealed twice	2 ball barings , sealed twice
compatibility	Campagnolo 9/10/11-Speed Shimano 9/10/11-Speed, SRAM 10/11-Speed	
	SRAM XX1	
weight	212 g	110 g

XeNTiS TRIA	specifications rear wheel	specifications front wheel
 <p>XeNTiS XMT (MARK2 TT) XH003 (BLADE)</p>		
range of use	BLADE / MARK2 TT	
quick release	QR5-135mm	QR5-100 mm
body material	aluminium	aluminium
axle	Ø 15 mm aluminium axle	Ø 10 mm aluminium axle
ball bearing	4 ball barings , sealed twice	2 ball barings , sealed twice
compatibility	Campagnolo 9/10/11-Speed Shimano 9/10/11-Speed, SRAM 10/11-Speed	
weight	120 g	55 g

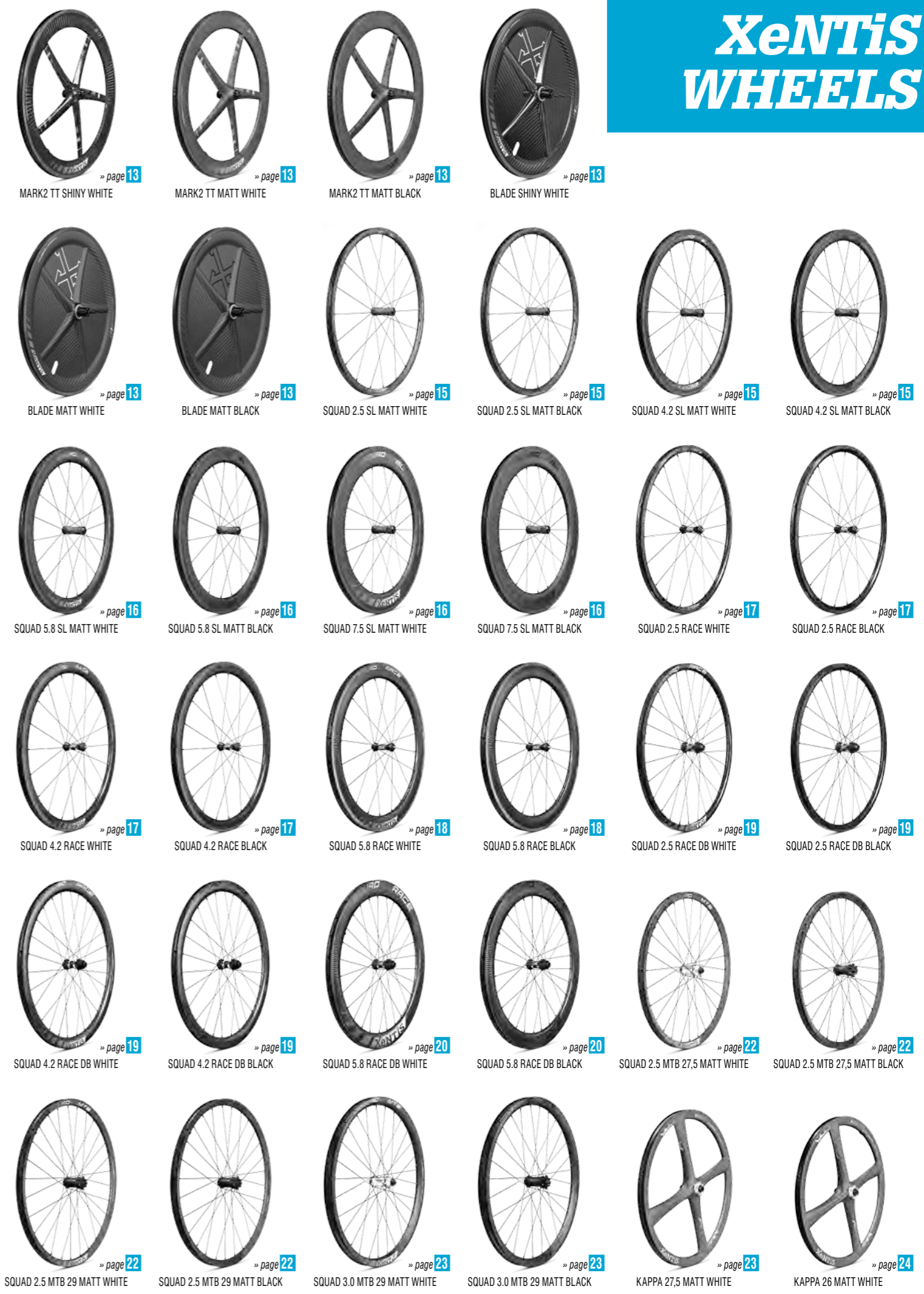



	AERODYNAMIC		CROSS WIND STABILITY		ATHLETE	
	Low	High	Stable	Unstable	Beginner	Professional
TRIA						
MARK2 TT						
BLADE						

Natascha Schmitt - Ironman Luxemburg









TRIA	MARK2 TT tubular	MARK2 TT tubeless ready	BLADE tubular	BLADE tubeless ready
design:	SHINY WHITE / MATT WHITE / MATT BLACK	SHINY WHITE / MATT WHITE / MATT BLACK	SHINY WHITE / MATT WHITE / MATT BLACK	SHINY WHITE / MATT WHITE / MATT BLACK
carbon fiber:	12K-Carbon	12K-Carbon	12K-Carbon	12K-Carbon
dimension:	28" x 24,6	622 x 18C tubeless ready	28" x 24,6	622 x 18C tubeless ready
tyres:	tubular 28" 22 - 28mm	clincher 22-25mm	tubular 28" 22 - 28mm	clincher 22-25mm
tyre inflation pressure:	15,0 bar / 220 psi	9,0 bar (22-622)/130 psi in 22-622 9,0 bar (23-622)/130 psi in 23-622 7,5 bar (25-622)/116 psi in 25-622	15,0 bar / 220 psi	9,0 bar (22-622)/130 psi in 22-622 9,0 bar (23-622)/130 psi in 23-622 7,5 bar (25-622)/116 psi in 25-622
brake surface:	XBP CARBON (patentiert / patented)	XBP CARBON (patentiert / patented)	XBP CARBON (patentiert / patented)	XBP CARBON (patentiert / patented)
cutaway view				
	front wheel   rear wheel	front wheel   rear wheel	front wheel   rear wheel	front wheel   rear wheel
rim depth:	65mm	65mm	Disc	Disc
rim width:	24,6mm	24,6mm	24,6mm	24,6mm
spokes count:	5	5	-	-
hub front / rear:	XeNTIS XMT	XeNTIS XMT	XeNTIS XH003	XeNTIS XH003
compatibility:	Campagnolo 9/10/11-Speed Shimano 9/10/11-Speed SRAM 10/11-Speed	Campagnolo 9/10/11-Speed Shimano 9/10/11-Speed SRAM 10/11-Speed	Campagnolo 9/10/11-Speed Shimano 9/10/11-Speed SRAM 10/11-Speed	Campagnolo 9/10/11-Speed Shimano 9/10/11-Speed SRAM 10/11-Speed
accessoires:	XeNTIS warranty card / XeNTIS Wheelbag / XeNTIS quick release / XeNTIS valve extenders for SV	XeNTIS warranty card / XeNTIS Wheelbag / XeNTIS quick release / XeNTIS Rim tape	XeNTIS warranty card / XeNTIS Wheelbag / XeNTIS quick release / XeNTIS valve extenders for SV / XeNTIS valve adapter	XeNTIS warranty card / XeNTIS Wheelbag / XeNTIS quick release / XeNTIS Rim tape XeNTIS valve adapter
weight per set:	SHINY WHITE: 1796g / MATT WHITE: 1756g / MATT BLACK: 1756g	SHINY WHITE: 1843g / MATT WHITE: 1793g / MATT BLACK: 1893g	SHINY WHITE: 1013g / WHITE MATT: 993g / MATT BLACK: 993g	SHINY WHITE: 1114g / WHITE MATT: 1094g / MATT BLACK: 1094g
max. combined weight:	120kg	120kg	120kg	120kg





	AERODYNAMIC		CROSS WIND STABILITY		ATHLETE	
	Low	High	Stable	Unstable	Beginner	Professional
<b>ROAD</b>						
<b>SQUAD 2.5 RACE</b>						
<b>SQUAD 4.2 RACE</b>						
<b>SQUAD 5.8 RACE</b>						
<b>SQUAD 2.5 SL</b>						
<b>SQUAD 4.2 SL</b>						
<b>SQUAD 5.8 SL</b>						
<b>SQUAD 7.5 SL</b>						
<b>ROAD DISC BRAKE</b>						
<b>SQUAD 2.5 RACE</b>						
<b>SQUAD 4.2 RACE</b>						
<b>SQUAD 5.8 RACE</b>						



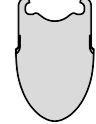

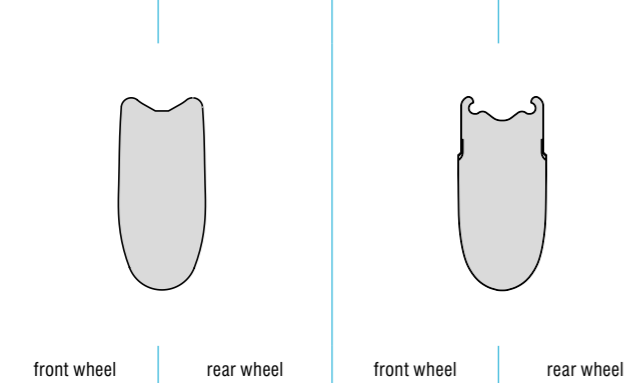
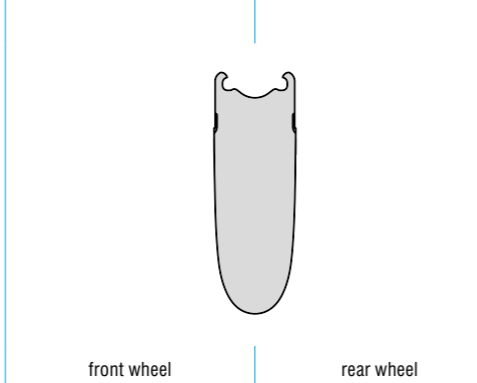
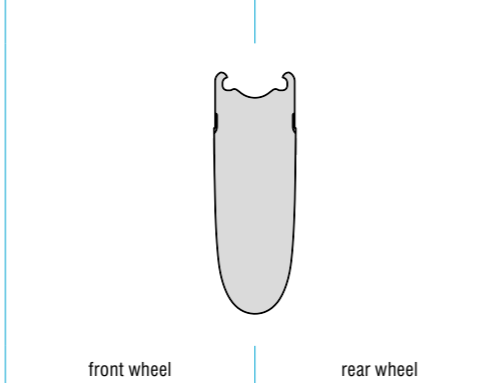

Nadja Pfeiling - Radmarathon

ROAD	SQUAD 2.5 SL tubular	SQUAD 2.5 SL tubeless ready	SQUAD 4.2 SL tubular	SQUAD 4.2 SL tubeless ready
	 		 	
design	MATT WHITE (MATT BLACK)	MATT WHITE (MATT BLACK)	MATT WHITE (MATT BLACK)	MATT WHITE (MATT BLACK)
carbon fiber	UD-Carbon	UD-Carbon	UD-Carbon	UD-Carbon
dimension:	28" x 24,6 tubular	622 x 18C tubeless ready	28" x 24,6 tubular	622 x 18C tubeless ready
tyres	tubular 28" 22 to 28mm	clincher 22-25mm	tubular 28" 22 to 28mm	clincher 22-25mm
tyre inflation pressure:	15,0 bar / 220 psi	9,0 bar (22-622)/130 psi in 22-622 9,0 bar (23-622)/130 psi in 23-622 7,5 bar (25-622)/116 psi in 25-622	15,0 bar / 220 psi	9,0 bar (22-622)/130 psi in 22-622 9,0 bar (23-622)/130 psi in 23-622 7,5 bar (25-622)/116 psi in 25-622
brake surface:	XBP CARBON (patentiert / patented)	XBP CARBON (patentiert / patented)	XBP CARBON (patentiert / patented)	XBP CARBON (patentiert / patented)
cutaway view				
	front wheel   rear wheel	front wheel   rear wheel	front wheel   rear wheel	front wheel   rear wheel
rim depth:	25mm	25mm	42mm	42mm
rim width:	24,6mm	24,6mm	24,6mm	24,6mm
spokes count:	20/24 (1:1)	20/24 (1:1)	20/24 (1:1)	20/24 (1:1)
hub front / rear:	XeNTiS XH003-Carbon / DT SWISS 240S	XeNTiS XH003-Carbon / DT SWISS 240S	XeNTiS XH003-Carbon / DT SWISS 240S	XeNTiS XH003-Carbon / DT SWISS 240S
compatibility:	Campagnolo 9/10/11-Speed Shimano 9/10/11-Speed SRAM 10/11-Speed	Campagnolo 9/10/11-Speed Shimano 9/10/11-Speed SRAM 10/11-Speed	Campagnolo 9/10/11-Speed Shimano 9/10/11-Speed SRAM 10/11-Speed	Campagnolo 9/10/11-Speed Shimano 9/10/11-Speed SRAM 10/11-Speed
accessoires:	XeNTiS warranty card / XeNTiS Wheelbag / XeNTiS quick release	XeNTiS warranty card / XeNTiS Wheelbag / XeNTiS quick release / XeNTiS Rim tape	XeNTiS warranty card / XeNTiS Wheelbag / XeNTiS quick release / XeNTiS valve extenders for SV	XeNTiS warranty card / XeNTiS Wheelbag / XeNTiS quick release / XeNTiS Rim tape
weight per set:	MATT WHITE : 1041g / MATT BLACK: 1041g	MATT WHITE : 1223g / MATT BLACK: 1223g	MATT WHITE : 1176g / MATT BLACK: 1176g	MATT WHITE : 1332g / MATT BLACK: 1332g
max. combined weight:	110kg	100kg	110kg	100kg

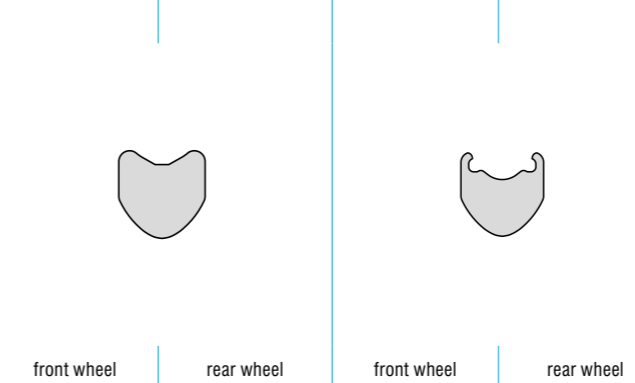
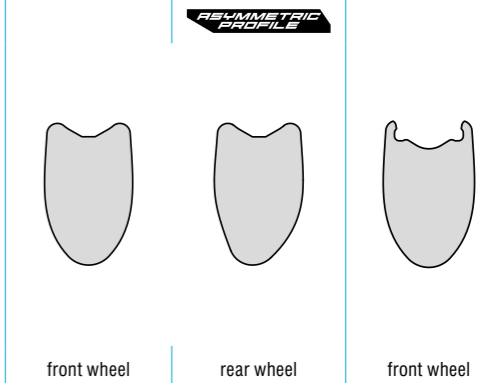
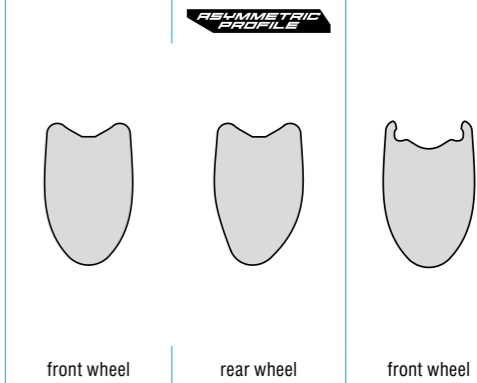
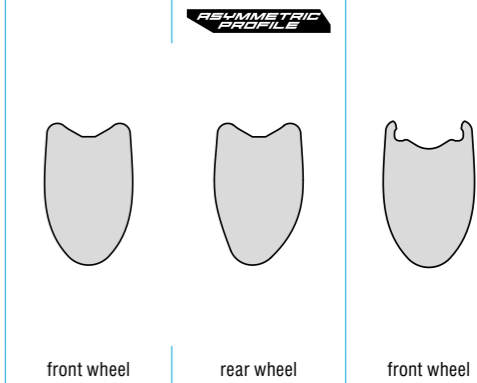

ROAD	SQUAD 5.8 SL tubular	SQUAD 5.8 SL tubeless ready	SQUAD 7.5 SL tubeless ready
			
design	MATT WHITE (MATT BLACK)	MATT WHITE (MATT BLACK)	MATT WHITE (MATT BLACK)
carbon fiber	UD-Carbon	UD-Carbon	UD-Carbon
dimension:	28" x 24,6	622 x 18C tubeless ready	622 x 18C tubeless ready
tyres	tubular 28" 22 - 28mm	clincher 22-25mm	clincher 22-25mm
tyre inflation pressure:	15,0 bar / 220 psi	9,0 bar (22-622)/130 psi in 22-622 9,0 bar (23-622)/130 psi in 23-622 7,5 bar (25-622)/116 psi in 25-622	9,0 bar (22-622)/130 psi in 22-622 9,0 bar (23-622)/130 psi in 23-622 7,5 bar (25-622)/116 psi in 25-622
brake surface:	XBP CARBON (patentiert / patented)	XBP CARBON (patentiert / patented)	XBP CARBON (patentiert / patented)
cutaway view			
rim depth:	58mm	58mm	75mm
rim width:	24,6mm	24,6mm	24,6mm
spokes count:	20/24 (1:1)	20/24 (1:1)	20/24 (1:1)
hub front / rear:	XeNTiS XH003-Carbon / DT SWISS 240S	XeNTiS XH003-Carbon / DT SWISS 240S	XeNTiS XH003-Carbon / DT SWISS 240S
compatibility:	Campagnolo 9/10/11-Speed Shimano 9/10/11-Speed SRAM 10/11-Speed	Campagnolo 9/10/11-Speed Shimano 9/10/11-Speed SRAM 10/11-Speed	Campagnolo 9/10/11-Speed Shimano 9/10/11-Speed SRAM 10/11-Speed
accessoires:	XeNTiS warranty card / XeNTiS Wheelbag / XeNTiS quick release / XeNTiS valve extenders for SV	XeNTiS warranty card / XeNTiS Wheelbag / XeNTiS quick release / XeNTiS Rim tape	XeNTiS warranty card / XeNTiS Wheelbag / XeNTiS quick release / XeNTiS Rim tape
weight per set:	MATT WHITE : 1315g / MATT BLACK: 1315g	MATT WHITE : 1447g / MATT BLACK: 1447g	MATT WHITE : 1797g / MATT BLACK: 1797g
max. combined weight:	110kg	100kg	100kg

ROAD	SQUAD 2.5 RACE tubular	SQUAD 2.5 RACE tubeless ready	SQUAD 4.2 RACE tubular	SQUAD 4.2 RACE tubeless ready
				
design	WHITE (BLACK)	WHITE (BLACK)	WHITE (BLACK)	WHITE (BLACK)
carbon fiber	3K-Carbon	3K-Carbon	3K-Carbon	3K-Carbon
dimension:	28" x 25 tubular	622 x 18C tubeless ready	28" x 26 tubular	622 x 18C tubeless ready
tyres	tubular 28" 22-28mm	clincher 22-25mm	tubular 28" 22-28mm	clincher 22-25mm
tyre inflation pressure:	15,0 bar / 220 psi	9,0 bar (22-622)/130 psi in 22-622 9,0 bar (23-622)/130 psi in 23-622 7,5 bar (25-622)/116 psi in 25-622	15,0 bar / 220 psi	9,0 bar (22-622)/130 psi in 22-622 9,0 bar (23-622)/130 psi in 23-622 7,5 bar (25-622)/116 psi in 25-622
brake surface:	XBP CARBON (patentiert / patented)	XBP CARBON (patentiert / patented)	XBP CARBON (patentiert / patented)	XBP CARBON (patentiert / patented)
cutaway view				
rim depth:	25mm	25mm	42mm	42mm
rim width:	25mm	25mm	26mm	26mm
spokes count:	20/24 (1:1)	20/24 (1:1)	20/24 (1:1)	20/24 (1:1)
hub front / rear:	DT SWISS 350	DT SWISS 350	DT SWISS 350	DT SWISS 350
compatibility:	Campagnolo 9/10/11-Speed Shimano 9/10/11-Speed SRAM 10/11-Speed	Campagnolo 9/10/11-Speed Shimano 9/10/11-Speed SRAM 10/11-Speed	Campagnolo 9/10/11-Speed Shimano 9/10/11-Speed SRAM 10/11-Speed	Campagnolo 9/10/11-Speed Shimano 9/10/11-Speed SRAM 10/11-Speed
accessoires:	XeNTiS warranty card / XeNTiS Wheelbag / XeNTiS quick release	XeNTiS warranty card / XeNTiS Wheelbag / XeNTiS quick release / XeNTiS Rim tape	XeNTiS warranty card / XeNTiS Wheelbag / XeNTiS quick release / XeNTiS valve extenders for SV	XeNTiS warranty card / XeNTiS Wheelbag / XeNTiS quick release / XeNTiS Rim tape
weight per set:	WHITE: 1183/ BLACK: 1183g	WHITE: 1363g/ BLACK: 1363g	WHITE: 1383g/ BLACK: 1383g	WHITE: 1543g/ BLACK: 1543g
max. combined weight:	110kg	100kg	110kg	100kg



ROAD	SQUAD 5.8 RACE tubular	SQUAD 5.8 RACE tubeless ready
design	WHITE (BLACK)	WHITE (BLACK)
carbon fiber	3K-Carbon	3K-Carbon
dimension:	28" x 26 tubular	622 x 18C tubeless ready
tyres	tubular 28" 22-28mm	clincher 22-25mm
tyre inflation pressure:	15,0 bar / 220 psi	9,0 bar (22-622)/130 psi in 22-622 9,0 bar (23-622)/130 psi in 23-622 7,5 bar (25-622)/116 psi in 25-622
brake surface:	XBP CARBON (patentiert / patented)	XBP CARBON (patentiert / patented)
cutaway view		
rim depth:	58mm	58mm
rim width:	26mm	26mm
spokes count:	20/24 (1:1)	20/24 (1:1)
hub front / rear:	DT SWISS 350	DT SWISS 350
compatibility:	Campagnolo 9/10/11-Speed Shimano 9/10/11-Speed SRAM 10/11-Speed	Campagnolo 9/10/11-Speed Shimano 9/10/11-Speed SRAM 10/11-Speed
accessoires:	XeNTIS warranty card / XeNTIS Wheelbag / XeNTIS quick release / XeNTIS valve extenders for SV	XeNTIS warranty card / XeNTIS Wheelbag / XeNTIS quick release / XeNTIS Rim tape
weight per set:	WHITE: 1543g / BLACK: 1543g	WHITE: 1663g / BLACK: 1663g
max. combined weight:	110kg	100kg

ROAD	SQUAD 2.5 RACE DB tubular	SQUAD 2.5 RACE DB tubeless ready	SQUAD 4.2 RACE DB tubular	SQUAD 4.2 RACE DB tubeless ready
design	WHITE (BLACK)	WHITE (BLACK)	WHITE (BLACK)	WHITE (BLACK)
carbon fiber	3K-Carbon	3K-Carbon	3K-Carbon	3K-Carbon
dimension:	28" x 25 tubular	622 x 18C tubeless ready	28" x 26 tubular	622 x 18C tubeless ready
tyres	tubular 28" 22-28mm	clincher 22-25mm	tubular 28" 22-28mm	clincher 22-25mm
tyre inflation pressure:	15,0 bar / 220 psi	9,0 bar (22-622)/130 psi in 22-622 9,0 bar (23-622)/130 psi in 23-622 7,5 bar (25-622)/116 psi in 25-622	15,0 bar / 220 psi	9,0 bar (22-622)/130 psi in 22-622 9,0 bar (23-622)/130 psi in 23-622 7,5 bar (25-622)/116 psi in 25-622
brake surface:	none	none	none	none
cutaway view				
rim depth:	25mm	25mm	42mm	42mm
rim width:	25mm	25mm	26mm	26mm
spokes count:	28/28 (1:1)	28/28 (1:1)	28/28 (1:1)	28/28 (1:1)
hub front / rear:	DT SWISS 350, SP, Center Lock®	DT SWISS 350, SP, Center Lock®	DT SWISS 350, SP, Center Lock®	DT SWISS 350, SP, Center Lock®
compatibility:	Campagnolo 9/10/11-Speed Shimano 9/10/11-Speed SRAM 10/11-Speed, SRAM XX1	Campagnolo 9/10/11-Speed Shimano 9/10/11-Speed SRAM 10/11-Speed, SRAM XX1	Campagnolo 9/10/11-Speed Shimano 9/10/11-Speed SRAM 10/11-Speed, SRAM XX1	Campagnolo 9/10/11-Speed Shimano 9/10/11-Speed SRAM 10/11-Speed, SRAM XX1
accessoires:	XeNTIS warranty card / XeNTIS Wheelbag	XeNTIS warranty card / XeNTIS Rim tape / XeNTIS Wheelbag	XeNTIS warranty card / XeNTIS Wheelbag / XeNTIS valve extenders for SV	XeNTIS warranty card / XeNTIS Rim tape / XeNTIS Wheelbag
weight per set:	WHITE: 1286g / BLACK: 1268g	WHITE: 1466g / BLACK: 1466g	WHITE: 1486g / BLACK: 1486g	WHITE: 1646g / BLACK: 1646g
max. combined weight:	110kg	110kg	110kg	110kg



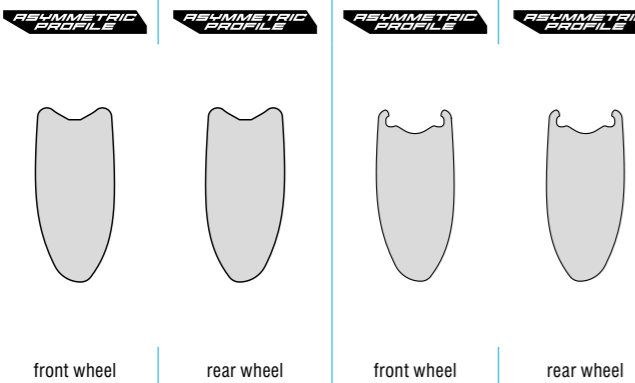



ROAD	SQUAD 5.8 RACE DB tubular	SQUAD 5.8 RACE DB tubeless ready
		
design	WHITE (BLACK)	WHITE (BLACK)
carbon fiber	3K-Carbon	3K-Carbon
dimension:	28" x 26 tubular	622 x 18C tubeless ready
tyres	tubular 28" 22-28mm	clincher 22-25mm
tyre inflation pressure:	15,0 bar / 220 psi	9,0 bar (22-622)/130 psi in 22-622 9,0 bar (23-622)/130 psi in 23-622 7,5 bar (25-622)/116 psi in 25-622
brake surface:	none	none
cutaway view		
rim depth:	58mm	58mm
rim width:	26mm	26mm
spokes count:	28/28 (1:1)	28/28 (1:1)
hub front / rear:	DT SWISS 350, SP, Center Lock®	DT SWISS 350, SP, Center Lock®
compatibility:	Campagnolo 9/10/11-Speed Shimano 9/10/11-Speed SRAM 10/11-Speed, SRAM XX1	Campagnolo 9/10/11-Speed Shimano 9/10/11-Speed SRAM 10/11-Speed, SRAM XX1
accessoires:	XeNTiS warranty card / XeNTiS Wheelbag / XeNTiS valve extenders for SV	XeNTiS warranty card / XeNTiS Rim tape / XeNTiS Wheelbag
weight per set:	WHITE: 1646g / BLACK: 1646g	WHITE: 1766g / BLACK: 1766g
max. combined weight:	110kg	110kg







MTB	PERFORMANCE		ATHLETE	
	Cross Country	All Mountain	Beginner	Professional
SQUAD 2.5 MTB 27.5	✓	✓	✓	✓
SQUAD 2.5 MTB 29	✓	✓	✓	✓
SQUAD 3.0 MTB 29	✓	✓	✓	✓
KAPPA 2 26	✓	✓	✓	✓
KAPPA 2 27,5	✓	✓	✓	✓

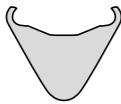
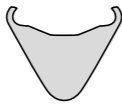
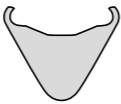
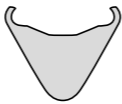



Benjamin Keil - MTB Marathon

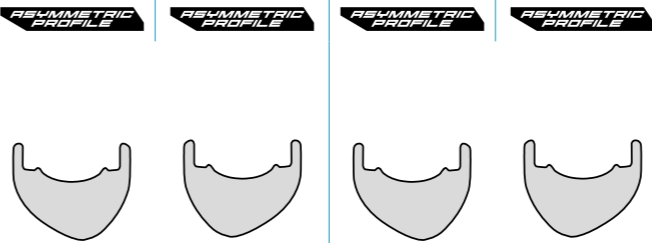
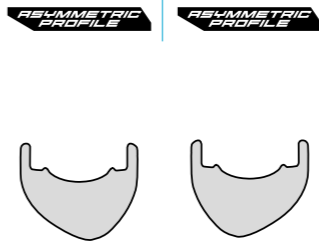

MTB	SQUAD 2.5 MTB 27,5	SQUAD 2.5 MTB 27,5 boost	SQUAD 2.5 MTB 29	SQUAD 2.5 MTB 29 BOOST
				
				
design	MATT WHITE (MATT BLACK)	MATT WHITE (MATT BLACK)	MATT WHITE (MATT BLACK)	MATT WHITE (MATT BLACK)
carbon fiber	3K-Carbon	3K-Carbon	3K-Carbon	3K-Carbon
dimension:	584 x 25C tubeless ready	584 x 25C tubeless ready	622 x 25C tubeless ready	622 x 25C tubeless ready
tyres	clincher 47-584 to 60-584	clincher 47-584 to 60-584	clincher 47-622 to 60-622	clincher 47-622 to 60-622
tyre inflation pressure:	3,5 bar (27,5x1,85 Zoll) / 50 psi in 47-584 ETRTO 3 bar (27,5x2,10 Zoll) / 43 psi in 54-584 ETRTO 2,7bar (27,5x2,25 Zoll) / 37 psi in 57-584 ETRTO 2,4 bar (27,5x2,35 Zoll) / 34 psi in 60-584 ETRTO	3,5 bar (27,5x1,85 Zoll) / 50 psi in 47-584 ETRTO 3 bar (27,5x2,10 Zoll) / 43 psi in 54-584 ETRTO 2,7bar (27,5x2,25 Zoll) / 37 psi in 57-584 ETRTO 2,4 bar (27,5x2,35 Zoll) / 34 psi in 60-584 ETRTO	3,5 bar (29x1,75 Zoll) / 50 psi in 47-622 ETRTO 3 bar (29x2,10 Zoll) / 43 psi in 54-622 ETRTO 2,7bar (29x2,25 Zoll) / 37 psi in 57-622 ETRTO 2,4 bar (29x2,35 Zoll) / 34 psi in 60-622 ETRTO	3,5 bar (29x1,75 Zoll) / 50 psi in 47-622 ETRTO 3 bar (29x2,10 Zoll) / 43 psi in 54-622 ETRTO 2,7bar (29x2,25 Zoll) / 37 psi in 57-622 ETRTO 2,4 bar (29x2,35 Zoll) / 34 psi in 60-622 ETRTO
brake surface:	none	none	none	none
cutaway view				
	front wheel   rear wheel	front wheel   rear wheel	front wheel   rear wheel	front wheel   rear wheel
rim depth:	25mm	25mm	25mm	25mm
rim width:	30,2mm	30,2mm	30,2mm	30,2mm
spokes count:	28/28	28/28	28/28	28/28
hub front / rear:	XeNTiS XH002-W / B	XeNTiS XH002-BO (QR15-110 / X12-148)	XeNTiS XH002-W / B	XeNTiS XH002-BO (QR15-110 / X12-148)
compatibility:	Shimano 9/10/11-Speed SRAM 10/11-Speed SRAM XX1	Shimano 9/10/11-Speed SRAM 10/11-Speed SRAM XX1	Shimano 9/10/11-Speed SRAM 10/11-Speed SRAM XX1	Shimano 9/10/11-Speed SRAM 10/11-Speed SRAM XX1
accessoires:	XeNTiS warranty card / XeNTiS Rim tape / XeNTiS Wheelbag XeNTiS quick release (only QR5)	XeNTiS warranty card / XeNTiS Rim tape / XeNTiS Wheelbag XeNTiS quick release (only QR5)	XeNTiS warranty card / XeNTiS Rim tape / XeNTiS Wheelbag XeNTiS quick release (only QR5)	XeNTiS warranty card / XeNTiS Rim tape / XeNTiS Wheelbag XeNTiS quick release (only QR5)
weight per set:	MATT WHITE: 1231g / MATT BLACK: 1231g	MATT WHITE: 1231g / MATT BLACK: 1231g	WHITE MATT: 1295g / BLACK MATT: 1295g	WHITE MATT: 1295g / BLACK MATT: 1295g
max. combined weight:	90kg	90kg	90kg	90kg

MTB	SQUAD 3.0 MTB 29	SQUAD 3.0 MTB 29 BOOST	KAPPA2 27.5	KAPPA2 27.5 BOOST
				
				
design	MATT WHITE (MATT BLACK)	MATT WHITE (MATT BLACK)	MATT WHITE	MATT WHITE
carbon fiber	12K-Carbon	12K-Carbon	12K-Carbon	12K-Carbon
dimension:	622 x 30,5 Hookless, tubeless ready	622 x 30,5 Hookless, tubeless ready	584x25C 27.5" tubeless ready	584x25C 27.5" tubeless ready
tyres	clincher 47-622 to 60-622	clincher 47-622 to 60-622	clincher 28-584 to 60-584	clincher 28-584 to 60-584
tyre inflation pressure:	3,5 bar (29x1,75 Zoll) / 50 psi in 47-622 ETRTO 3 bar (29x2,10 Zoll) / 43 psi in 54-622 ETRTO 2,7bar (29x2,25 Zoll) / 37 psi in 57-622 ETRTO 2,4 bar (29x2,35 Zoll) / 34 psi in 60-622 ETRTO	3,5 bar (29x1,75 Zoll) / 50 psi in 47-622 ETRTO 3 bar (29x2,10 Zoll) / 43 psi in 54-622 ETRTO 2,7bar (29x2,25 Zoll) / 37 psi in 57-622 ETRTO 2,4 bar (29x2,35 Zoll) / 34 psi in 60-622 ETRTO	3,5 bar (27,5x1,85 Zoll) / 50 psi in 47-584 ETRTO 3 bar (27,5x2,10 Zoll) / 43 psi in 54-584 ETRTO 2,7bar (27,5x2,25 Zoll) / 37 psi in 57-584 ETRTO 2,4 bar (27,5x2,35 Zoll) / 34 psi in 60-584 ETRTO	3,5 bar (27,5x1,85 Zoll) / 50 psi in 47-584 ETRTO 3 bar (27,5x2,10 Zoll) / 43 psi in 54-584 ETRTO 2,7bar (27,5x2,25 Zoll) / 37 psi in 57-584 ETRTO 2,4 bar (27,5x2,35 Zoll) / 34 psi in 60-584 ETRTO
brake surface:	none	none	none	none
cutaway view				
	front wheel   rear wheel	front wheel   rear wheel	front wheel   rear wheel	front wheel   rear wheel
rim depth:	30mm	30mm	35mm	35mm
rim width:	36mm	36mm	30,2mm	30,2mm
spokes count:	28/28	28/28	4	4
hub front / rear:	XeNTiS XH002-W / B	XeNTiS XH002-BO (QR15-110 / X12-148)	XeNTiS XH002 (QR5-100 / QR5-135)	XeNTiS XH002-BO (QR15-110 / X12-148)
compatibility:	Shimano 9/10/11-Speed SRAM 10/11-Speed SRAM XX1	Shimano 9/10/11-Speed SRAM 10/11-Speed SRAM XX1	Shimano 9/10/11-Speed SRAM 10-Speed SRAM XX1	Shimano 9/10/11-Speed SRAM 10-Speed SRAM XX1
accessoires:	XeNTiS warranty card / XeNTiS Rim tape / XeNTiS Wheelbag	XeNTiS warranty card / XeNTiS Rim tape / XeNTiS Wheelbag	XeNTiS warranty card / XeNTiS Rim tape / XeNTiS Wheelbag / XeNTiS quick release (only QR5)	XeNTiS warranty card / XeNTiS Rim tape / XeNTiS Wheelbag
weight per set:	MATT WHITE: 1643g / MATT BLACK: 1643g	MATT WHITE: 1643g / MATT BLACK: 1643g	MATT WHITE : 1413g	MATT WHITE : 1433g
max. combined weight:	120kg	120kg	120kg	120kg

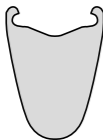

MTB	KAPPA2 26
	 
design	MATT WHITE
carbon fiber	12K-Carbon
dimension:	559x20C tubeless ready
tyres	clincher 28-559 to 60-559
tyre inflation pressure:	6 bar (26x1 Zoll) / 87 psi in 25-559 ETRTO 3,5 bar (26x1,85 Zoll) / 50 psi in 47-559 ETRTO 3 bar (26x2,10 Zoll) / 43 psi in 54-559 ETRTO 2,7bar (26x2,25 Zoll) / 37 psi in 57-559 ETRTO
brake surface:	none
cutaway view	
	<div style="display: flex; justify-content: space-around;"> <span>front wheel</span> <span>rear wheel</span> </div>
rim depth:	35mm
rim width:	25,6mm
spokes count:	4
hub front / rear:	XeNTiS XH002 (QR5-100 / QR5-135)
compatibility:	Shimano 9/10/11-Speed SRAM 10-Speed SRAM XX1
accessoires:	XeNTiS warranty card / XeNTiS Rim tape / XeNTiS Wheelbag / XeNTiS quick release (QR5)
weight per set:	MATT WHITE : 1297g
max. combined weight:	120kg



# SPARE PARTS

11XRS001



Rotor Shimano 11-speed (Nabe XMT) / Body Shimano 11-speed (hub XMT)

11XRC001



Rotor Campagnolo 11-speed (Nabe XMT) / Body Campagnolo 11-speed (hub XMT)

14XRS001



Rotor Shimano 11-speed (Nabe XH001) / Body Shimano 11-speed (hub XH001)

14XRC001



Rotor Campagnolo 11-speed (Nabe XH001) / Body Campagnolo 11-speed (hub XH001)

14XRS002



Rotor Shimano 11-speed (Nabe XH002-3) / Body Shimano 11-speed (hub XH002-3)

14XRC002



Rotor Campagnolo 11-speed (Nabe XH002-3) / Body Campagnolo 11-speed (hub XH002-3)

14XRX002



Rotor SRAM XX1 (Nabe XH002-3) / Body SRAM XX1 (hub XH002-3)



Zahnring / Ratchet system



Sperrklinke / Pawl system



11XSC002



Endanschlag ROAD /  
Hub spacer ROAD

13XSC...  
14XSC...



Endanschlag MTB /  
Hub spacer MTB

12XQRS001



Schnellspanner (SL) /  
Quick release (SL)

11XBBS...



Kugellager /  
Ball bearing

12XBBC...



Kugellager (Keramik) /  
Ball bearing (ceramic)

14XRS005



Distanzscheibe 1,8 mm (10- / 11-speed) /  
Freewheel spacer 1,8 mm (10- / 11-speed)

11XQR001



Schnellspanner (RACE) /  
Quick release (RACE)

11S001-



Speiche /  
Spoke

11NU001



Speichennippel (SAPIM) /  
Spoke nipple (SAPIM)

12XBPS001  
12XBPC001



XeNTIS Bremsbeläge /  
XeNTIS brake pads

17007

NEW  
PRODUCT



XeNTIS Ventiladapter (BLADE) /  
XeNTIS valve adapter (BLADE)

13XV001

NEW  
PRODUCT



XeNTIS Plastikabdeckung für Ventiloch /  
XeNTIS plastic cover for valve hole

11XSS001



Speichenwerkzeug /  
Spoke tool

13XRT...



Felgenband /  
Rim tape

12XV-HF20



Ventilverlängerung (HF20) /  
Valve extension (HF20)

17NU001

NEW  
PRODUCT



Speichennippel (DT Swiss) /  
Spoke nipple (DT Swiss)

12XV-HF40



Ventilverlängerung (HF40) /  
Valve extension (HF40)

12XV-HF60



Ventilverlängerung (HF60) /  
Valve extension (HF60)

11XA006



Achse (BAHN) /  
Axle (TRACK)

Weitere Ersatzteile auf Anfrage. / Further spare parts on request.



**17001**  
**XeNTiS** - Herren Funktionsshirt,  
 100% Polyester,  
 Größen S - XL

**17001**  
**XeNTiS** - Men's functional  
 shirt, 100% polyester,  
 sizes S - XL



**X0300S**  
**XeNTiS** - Kappe schwarz,  
 atmungsaktiv, Einheitsgröße  
**X0300S**  
**XeNTiS** - cap black,  
 breathable, unisize



**X0300W**  
**XeNTiS** - Kappe weiß,  
 atmungsaktiv, Einheitsgröße  
**X0300W**  
**XeNTiS** - cap white,  
 breathable, unisize



**17002**  
**XeNTiS** - Damen Funktionsshirt,  
 100% Polyester,  
 Größen S - XL

**17002**  
**XeNTiS** - Women's functional  
 shirt, 100% polyester,  
 sizes S - XL

**17006**  
**XeNTiS** - Trinkflasche,  
 800 ml

**17006**  
**XeNTiS** - bottle,  
 800 ml



**11XWHEELBAG1 / 11XWHEELBAG2**  
**XeNTiS** - wheel bag mit 2 Fächern für 2 Räder und extra Polsterung,  
 extra Innentasche, Befestigungskordel für jedes Rad  
 Größe: 81x80x13 cm / (81x80x19 cm. 11XWHEELBAG2)

**11XWHEELBAG1 / 11XWHEELBAG2**  
**XeNTiS** - wheel bag, with 2 compartments for 2 wheels and extra  
 padding, separate inner pocket, fixation cord for each wheel  
 size: 81x80x13 cm / (81x80x19 cm. 11XWHEELBAG2)



**16002**  
**XeNTiS** - Trikot kurzarm mit durchgehendem Zipp,  
 aerodynamischer Schnitt, 100% Polyester,  
 Größen S - X

**16002**  
**XeNTiS** - jersey short sleeves with full zipp, fitted  
 aerodynamically, 100% polyester,  
 sizes S - XL



**16001**  
**XeNTiS** - Radhose kurz mit Träger,  
 höchste Qualität, 73% Nylon,  
 27% Spandex,  
 Größen S - XL

**16001**  
**XeNTiS** - cycling bib shorts,  
 premium quality, 73% nylon,  
 27% spandex,  
 sizes S - XL



**11003**  
**XeNTiS** - Ärmlinge,  
 100% Lycra

**11003**  
**XeNTiS** - arm warmers,  
 100 % lycra



**11005**  
**XeNTiS** - Fahrradsocken, atmungsaktiv,  
 70% Baumwolle, 21% Lycra,  
 5% Elasthan, 4% Polyamid

**11005**  
**XeNTiS** - cycling socks, breathable,  
 70% cotton, 21% lycra,  
 5% elasthan, 4% polyamid



**11004**  
**XeNTiS** - Fahrrad Handschuhe,  
 strapazierfähige, elastische  
 Obermaterialien

**11004**  
**XeNTiS** - cycling gloves, sturdy,  
 flexible upper materials









**XeNTIS**  
carbon technology

**HIGH-END WHEELS & MORE**

**Ihr Partner in allen Fragen zur Faserverbundwerkstoff-Technologie.**  
XeNTIS fertigt nicht nur Carbon Felgen für Laufräder, sondern auch verschiedene Sicht- und Strukturbauteile.  
Egal, welche Bauteile Sie realisieren wollen, wir freuen uns auf Ihre Anfrage.

**Your professional partner in fiber-reinforced composite technology.**  
XeNTIS does not only produce carbon rims for wheels, but also different cosmetic and structural components.  
Whatever component you would like to realize, please do not hesitate to contact us with your enquiry.

**XeNTIS**  
carbon wheel technology

XeNTIS Composite Entwicklungs- und Produktions GmbH  
Dr. Niederdorferstraße 25, 8572 Bärnbach, Austria  
Tel.: +43 (0)3142-60945-0, Fax: +43 (0)3142-60945-690  
office@xentis.com, www.xentis.com

XeNTIS Produkte können Abweichungen enthalten, Spezifikationen können ohne vorherige Ankündigungen geändert werden.  
Gewichtsschwankungen können aufgrund der Produktionsmethode des Laufrades auftreten. Irrtümer und Änderungen vorbehalten!  
XeNTIS products may not be exactly as shown, specifications subject to change without notice. Weight tolerances may occur due to the manufacturing process. Errors and omissions excepted!

ID/E 06/17 | X0220E-16